

B AJ-166-CP

ITEM #	PART #	QTY	DESCRIPTION
1	SEE TABLE #1	1	HOUSING - JACK, CABLE
2	AJ-166-30	1	INSERT 6-COND, SOLDER
3	AP-105-5	1	STRAIN RELIEF
4	AP-116-3	1	WASHER, RUBBER
5	AP-116-7	1	ADAPTER, NUT
6	SEE TABLE #1	1	BUSHING
7	SEE TABLE #1	1	WASHER
8	SEE TABLE #1	1	SPRING
9	AP-116-6	1	STUD

TABLE #1						
PART NUMBER	MILITARY PART NO.	CABLE SIZE	HOUSING	BUSHING	WASHER	SPRING
AJ-166/14-1	M55116/14-1	.165 ±.010	AJ-156-11/14-1	AP-116-17	AP-116-2	AP-116-4
AJ-166/14-2	M55116/14-2	.228 ±.010	AJ-156-11/14-2	AP-116-18	AP-116-2	AP-116-4
AJ-166/14-3	M55116/14-3	.250 ±.010	AJ-156-11/14-3	AP-116-8	AP-116-2	AP-116-4
AJ-166/14-4	M55116/14-4	.290 ±.010	AJ-156-11/14-4	AP-116-19	AP-116-2	AP-116-4
AJ-166/14-5	M55116/14-5	.320 ±.010	AJ-156-11/14-5	AP-116-20	AP-116-22	AP-116-21

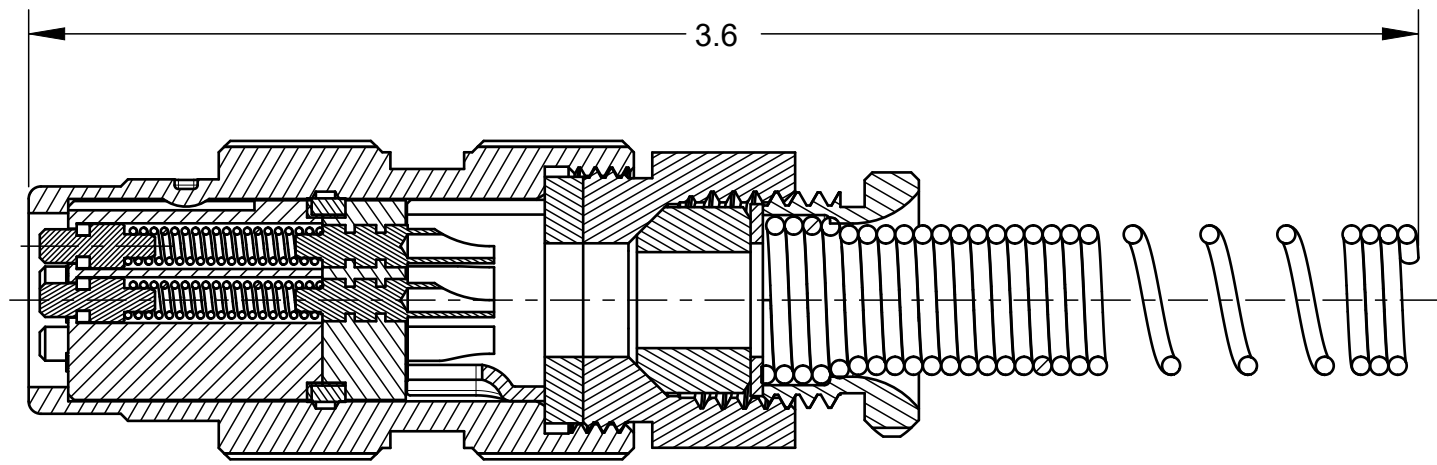
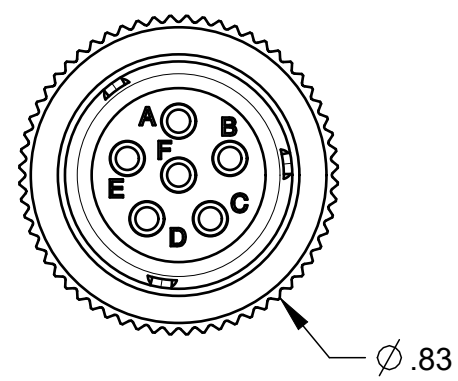
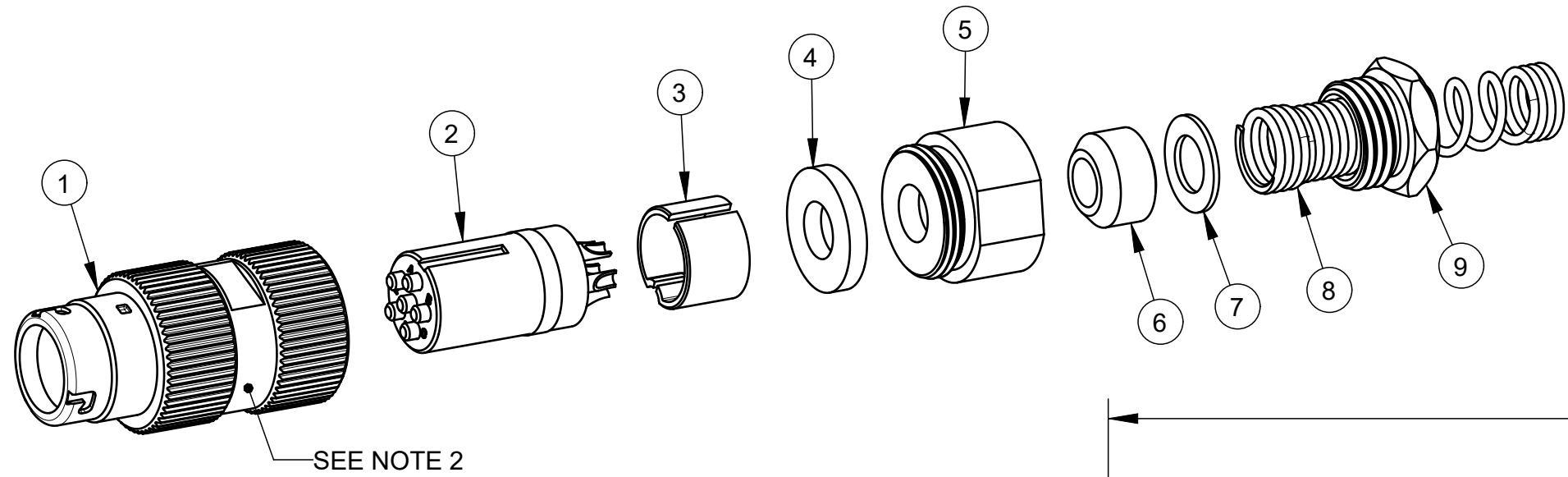

NOTES;
 1. CONNECTORS ARE QUALIFIED TO MIL-DTL-55116.
 2. MARK MILITARY PART IDENTIFYING NO. LOCATED APPROXIMATELY AS SHOWN.

THIS DOCUMENT CONTAINS PROPRIETARY INFORMATION OF NEXUS, INCORPORATED AND SUCH INFORMATION MAY NOT BE DISCLOSED TO OTHERS FOR ANY PURPOSE OR USED FOR ANY PURPOSE WITHOUT THE WRITTEN CONSENT OF NEXUS.

LET.	REVISION	CN #	DATE	CHK.
D	CHG NOTE #2	1223	10/23 2018	SPL
C	ADD: AJ-166/14-5	213	10/7 2014	HR
B	UNDER BUSHING "SEE TABLE" WAS "SEE NOTE 2".	040	1/4/10	GPH
A	ADD NOTES 1 AND 2 AND TABLE	037	12/18/09	GPH

DWN.BY	GPH	DATE	13-Jul-09
CHECKED BY		DATE	
APPR.BY		DATE	

UNLESS OTHERWISE SPECIFIED:
 DIMENSIONS ARE IN INCHES &/OR [mm]
 TOLERANCES:
 DECIMAL: .XX[X.X] .XXX[X.XX]
 ±.01[0.3] ±.003[0.08]
 FRACTION: X/X ±1/64
 ANGLES: .X ±.5

MATERIAL	
FINISH	
WEIGHT	SCALE = 2.00 :1
TITLE	
JACK, 6 PIN AUDIO, SOLDER CUP	
DO NOT SCALE DWG.	SHEET 1 OF 1

NEXUS
 STAMFORD, CONN

SIZE **B** DWG. NO. **AJ-166-CP**