

NOTICE OF PROPRIETARY RIGHTS THIS DOCUMENT CONTAINS CONFIDENTIAL TECHNICAL DATA, INCLUDING TRADE SECRETS, PROPRIETARY TO TIMES MICROWAVE SYSTEMS. DISCLOSURE OF THIS DATA IS EXPRESSLY CONDITIONED UPON YOUR ASSENT THAT ITS USE IS LIMITED TO USE WITHIN YOUR COMPANY ONLY. ANY OTHER USE IS STRICTLY PROHIBITED WITHOUT THE PRIOR WRITTEN CONSENT OF TIMES MICROWAVE SYSTEMS.

SYM	REVISION DESCRIPTION	DFTM	DATE	APPD	DATE
A	RELEASED FOR PRODUCTION	D. J. H.	9/12/12	J. D. B.	9/21/12

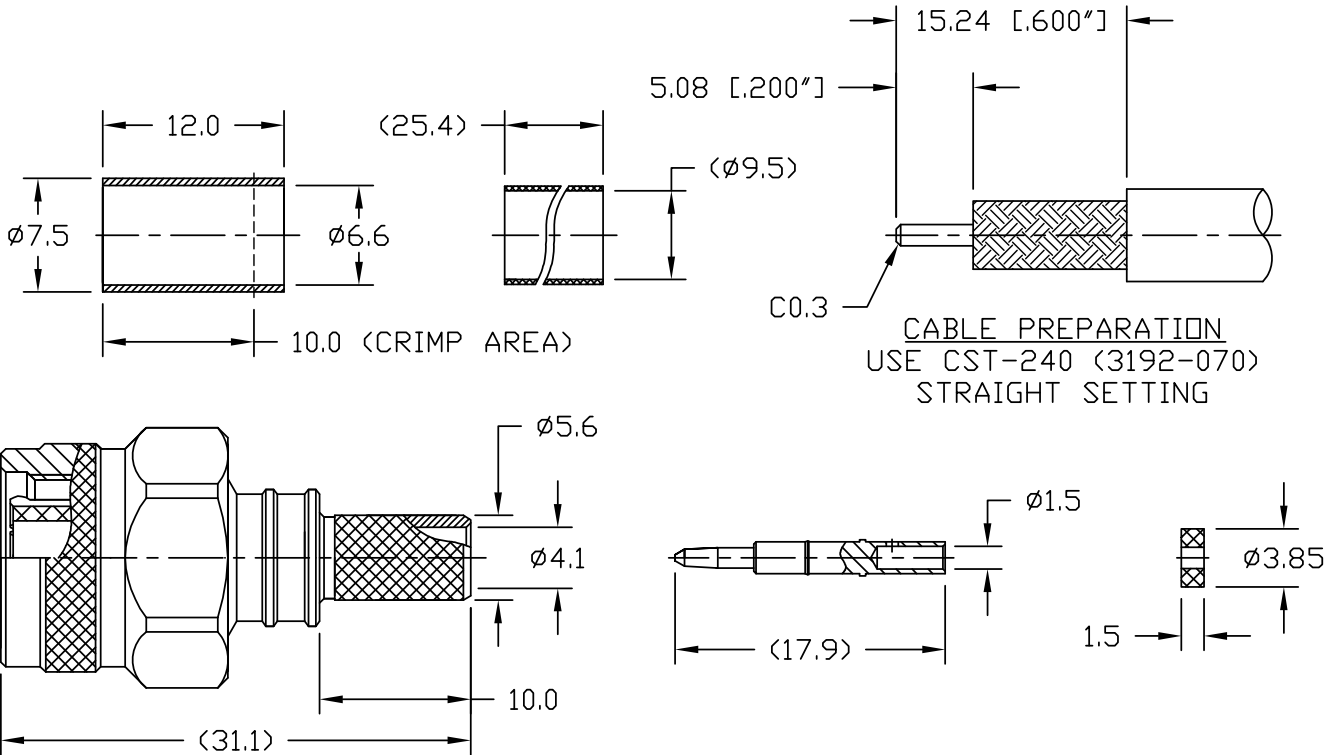

NOTES:

- CONTACT PIN IS SOLDERED.
- CRIMP THE FERRULE TO .255" HEX.

ALL PARTS SATISFIED ROHS REQUIREMENTS

MATERIALS AND PLATING		UNIT: MICRO-INCHES
BODY	BRASS C3604	ALBALOY 80u"/COPPER
CONTACT PIN	BRASS C3604	GOLD 50u"/COPPER
INSULATOR	TEFLON MIL-P-19468	NATURAL
FERRULE	BRASS	ALBALOY 80u"/COPPER

MECHANICAL CHARACTERISTICS	
Force to engage and disengage	N/A
Center contact retention force	6 lbs
Coupling recommend torque	4-6 in-lbs
Coupling nut retention force	100 lbs
Durability	≥ 500 cycles

ELECTRICAL CHARACTERISTICS	
Impedance	50 Ω
Voltage rating	500V(rms)
Frequency range	0~6GHz
Dielectric withstanding voltage	1000V
Contact resistance	Center contact ≤ 2.0mΩ Outer contact ≤ 0.2mΩ
Insulation resistance	≥ 5000MΩ
Insertion loss	According to the cable
RF-leakage	N/A
VSWR	1.3MAX@0-6GHz

ENVIRONMENTAL CHARACTERISTICS	
Temperature range	-65°C - +165°C
Vibration	MIL-STD-202, Method 204, Cond. B
Shock	MIL-STD-202, Method 213, Cond. I
Corrosion	MIL-STD-202, Method 101, Cond. B

MATL:	UNLESS OTHERWISE SPECIFIED ALL DIMENSIONS ARE IN mm MACHINED SURFACES FINISH 1.6 RMS MAX. REMOVE ALL BURRS 0.15X45° MAX. BREAK MACHINE CORNERS 0.15X45° MAX. FILLET R. TOLERANCES ON DECIMALS .X ± 0.3 .XX ± 0.2 ANGLES ± 1/2° FRACTIONS ± N/A	DFTM. D. J. H.	TIMES MICROWAVE SYSTEMS
		DATE 9/12/12	
USED ON: 0-2		CHKD. J. D. B.	TC-240-TM-X "TNC" MALE FOR LMR-240 CABLE SOLDER/CRIMP/NO BRAID TRIM
		DATE 9/21/12	
SCALE: N/A	DWG. SIZE A	APPD. J. D. B.	SHEET 1 of 1 SD3190-2797 REV A
		DO NOT SCALE DRAWING	
	CODE IDENT 68999	DATE 9/21/12	